



UNIVERSITY OF CAMBRIDGE INTERNATIONAL EXAMINATIONS
International General Certificate of Secondary Education

CANDIDATE
NAME

CENTRE
NUMBER

--	--	--	--	--

CANDIDATE
NUMBER

--	--	--	--

* 6 5 7 2 5 9 6 7 7 6 *

BIOLOGY

0610/61

Paper 6 Alternative to Practical

October/November 2013

1 hour

Candidates answer on the Question Paper

No Additional Materials are required.

READ THESE INSTRUCTIONS FIRST

Write your Centre number, candidate number and name on all the work you hand in.

Write in dark blue or black pen.

You may use a pencil for any diagrams or graphs.

Do not use staples, paper clips, highlighters, glue or correction fluid.

DO NOT WRITE IN ANY BARCODES.

Answer **all** questions.

Electronic calculators may be used.

You may lose marks if you do not show your working or if you do not use appropriate units.

At the end of the examination, fasten all your work securely together.

The number of marks is given in brackets [] at the end of each question or part question.

This document consists of **11** printed pages and **1** blank page.



1 Seeds from the plant family *Papilionaceae* form an important part of the human diet.

Fig. 1.1 shows three different types of seed that have been soaked in water for 24 hours.

For
Examiner's
Use



lentils



chickpeas



soya beans

Fig. 1.1

(a) Describe the differences in shape **and** appearance of the seed coat (testa) between the three types of seed.

Write your answers in Table 1.1.

Table 1.1

feature	lentil	chickpea	soya bean
shape of seed			
appearance of seed coat			

[3]

- (b) A group of students were planning an investigation into the effect of temperature on the germination of seeds.

*For
Examiner's
Use*

The teacher gave them a list of possible variables.

temperature	number of seeds germinated
intensity of light	time
length of seedling	volume of water

From this list, select the most suitable:

variable to change;

variable to measure.

[2]

Fig. 1.2 shows the same three seeds after they have been germinated in suitable conditions.

*For
Examiner's
Use*



Fig. 1.2

(c) (i) Make a large, labelled drawing of the **lentil** seedling.

[4]

(ii) You are going to calculate the magnification of your drawing.

Measure the length of the line **ST** on Fig. 1.2.

length of line **ST** mm

Draw line **ST** on your drawing in the same position as in Fig. 1.2.

Measure the corresponding length of **ST** on your drawing.

length of **ST** in drawing mm

Calculate the magnification of your drawing.

Show your working.

magnification \times [4]

Lentils contain protein and a small quantity of fat.

(d) Describe the food tests you could carry out to show that lentil seeds contain:

(i) protein;

.....
.....
.....
..... [2]

(ii) fat.

.....
.....
.....
.....
..... [3]

(e) The percentage of protein and fat in five types of seed, are shown in Table 1.2.

For
Examiner's
Use

Table 1.2

type of seed	percentage of protein / %	percentage of fat / %
chickpea	8.0	2.5
lentil	9.0	0.6
lima bean	8.0	0.4
mung bean	7.0	0.4
soya bean	16.0	8.0

- (i) Construct a bar chart to show the percentages of protein and fat in the five types of seed. Use the same axes for the two sets of data.

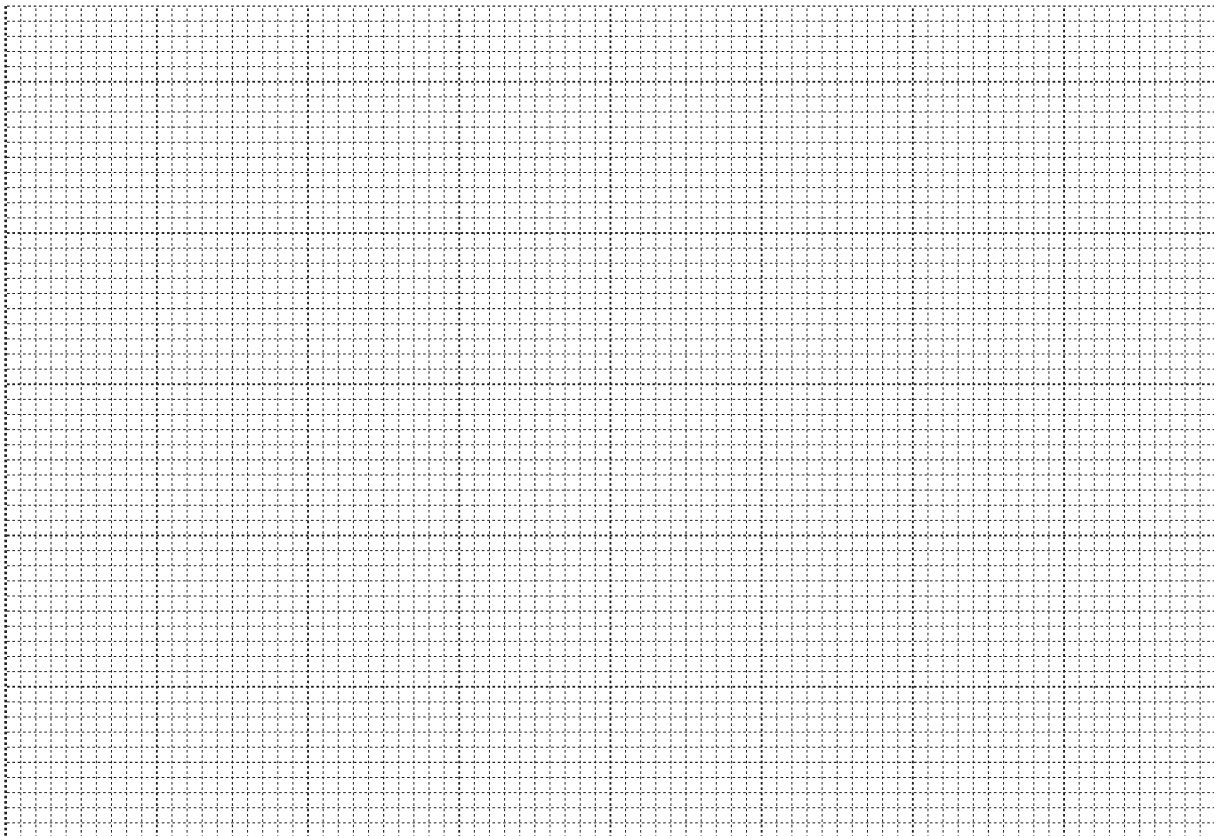

[5]

- (ii) Meat is a good source of protein.

Name the type of seed in Table 1.2 that would be a good alternative to meat in the human diet.

.....

[1]

Fig. 1.3 shows part of a label from a packet of soya bean seeds. The label shows the energy content measured in kilojoules.

For
Examiner's
Use

Soya Beans	
Nutrition	
Typical composition	50 g serving provides
Energy	230 kJ
Protein	8.5 g
Carbohydrate	4.5 g
Fat	4.0 g

Fig. 1.3

Fig. 1.4 shows a simple calorimeter. This apparatus can be used to find the energy content of a soya bean seed. The soya bean seed is burned and the energy released is absorbed by the water in the test-tube.

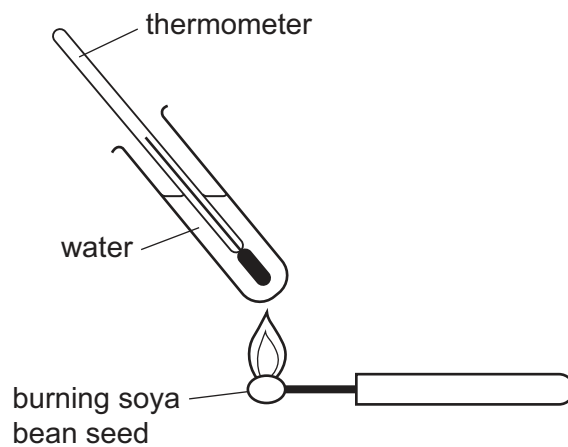

Fig. 1.4

(f) Suggest how you could **safely** carry out a simple investigation to find the energy content of a sample of soya bean seeds.

State what you would need to measure and control.

.....

.....

.....

.....

.....

.....

..... [3]

[Total: 27]

2 A student investigated the effect of solution **E** on cucumber.

A thin slice, approximately 2 mm thick, was cut from a cucumber as shown in Fig. 2.1.

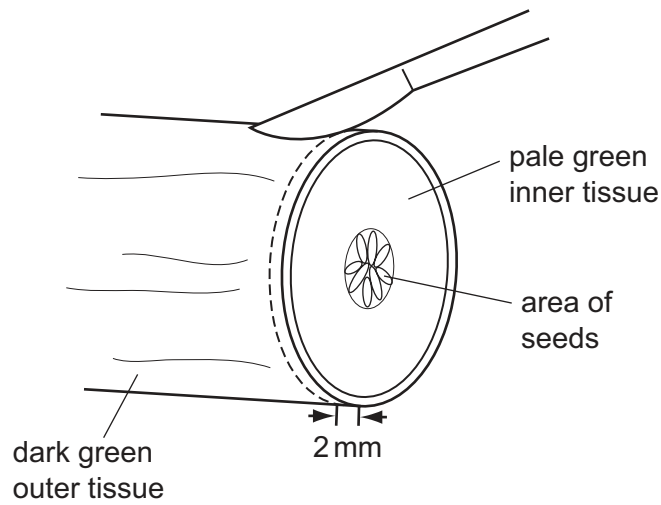

Fig. 2.1

The centre of the slice was removed as shown in Fig. 2.2A.

The slice was cut in half as shown in Fig. 2.2B.

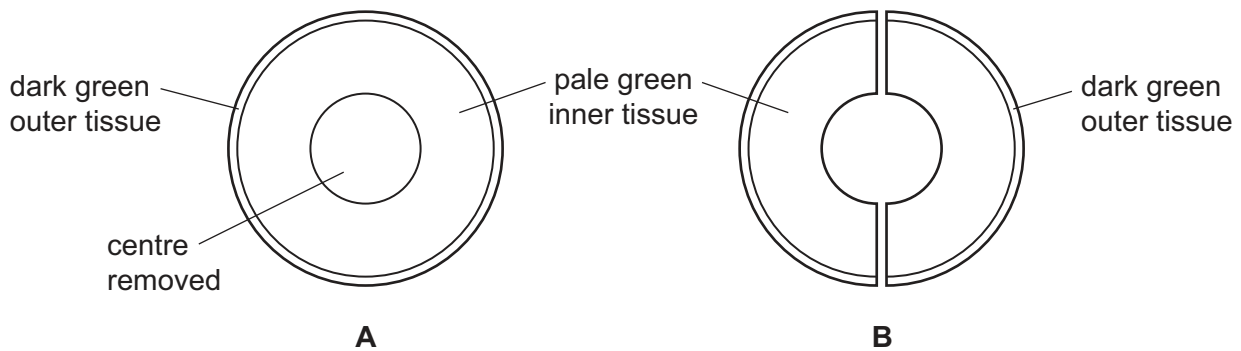
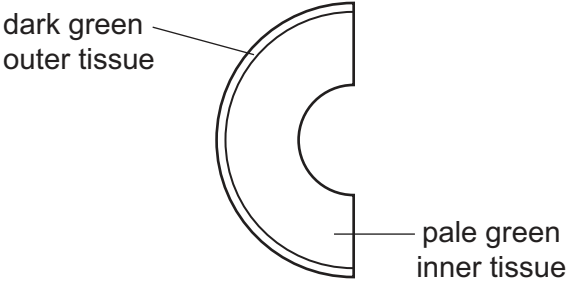
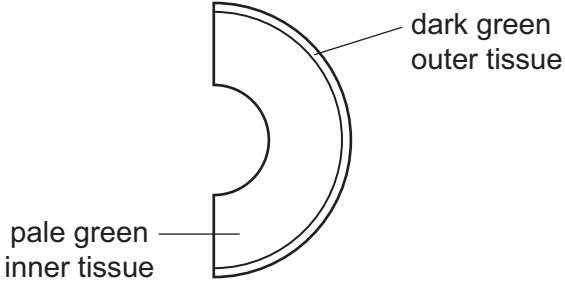
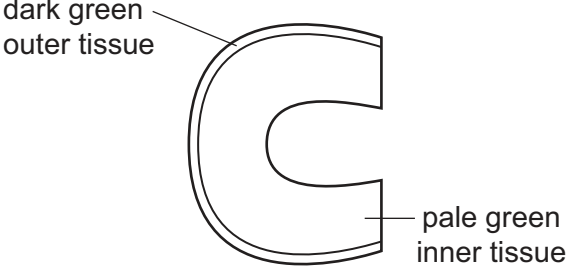
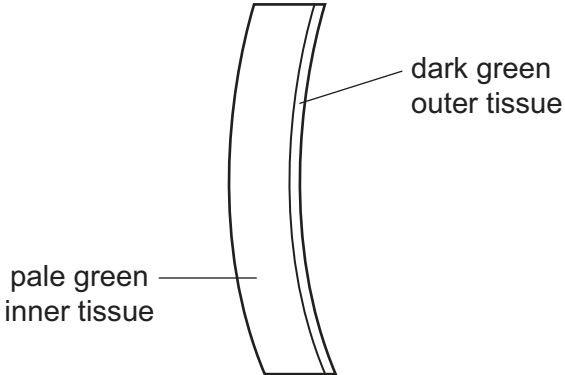

Fig. 2.2

One piece (half slice) of cucumber was placed in solution **E**.
 A second piece was placed in water.
 After 5 minutes the shape of the pieces in solution **E** and water had changed.
 Table 2.1 shows the pieces of cucumber before and after being placed in solution **E** and water.

Table 2.1

the shape of the piece of cucumber before being placed in solution E	the shape of the piece of cucumber before being placed in water
	
the shape of the piece of cucumber after being placed in solution E	the shape of the piece of cucumber after being placed in water
	

(a) Describe the effect of solution **E** and water on:

(i) the dark green outer tissue of the pieces of cucumber;

in solution **E**

.....

in water

..... [2]

(ii) the pale green inner tissue of the pieces of cucumber.

in solution **E**

.....

in water

..... [2]

(b) Explain the effect of solution **E** on the tissues of the cucumber.

.....

.....

.....

.....

.....

..... [3]

(c) State **one** possible source of error in the method used in this investigation.

Suggest a suitable improvement.

source of error

.....

improvement

..... [2]

[Total: 9]

3 Slugs and snails are molluscs that can live in water or on land.

Fig. 3.1 shows a slug and a snail.

For
Examiner's
Use



Fig. 3.1

(a) (i) Describe **two** features, **visible** in Fig. 3.1, that suggest the slug and the snail belong to the same group of molluscs.

- 1
- 2 [2]

(ii) Describe **one** difference, other than size, **visible** in Fig. 3.1, between the slug and the snail.

..... [1]

Fig. 3.2 shows a shell of a mollusc.



Fig. 3.2

(b) Suggest the importance of the shell to molluscs that belong to this group.

.....
..... [1]

[Total: 4]

Copyright Acknowledgements:

Permission to reproduce items where third-party owned material protected by copyright is included has been sought and cleared where possible. Every reasonable effort has been made by the publisher (UCLES) to trace copyright holders, but if any items requiring clearance have unwittingly been included, the publisher will be pleased to make amends at the earliest possible opportunity.

University of Cambridge International Examinations is part of the Cambridge Assessment Group. Cambridge Assessment is the brand name of University of Cambridge Local Examinations Syndicate (UCLES), which is itself a department of the University of Cambridge.